

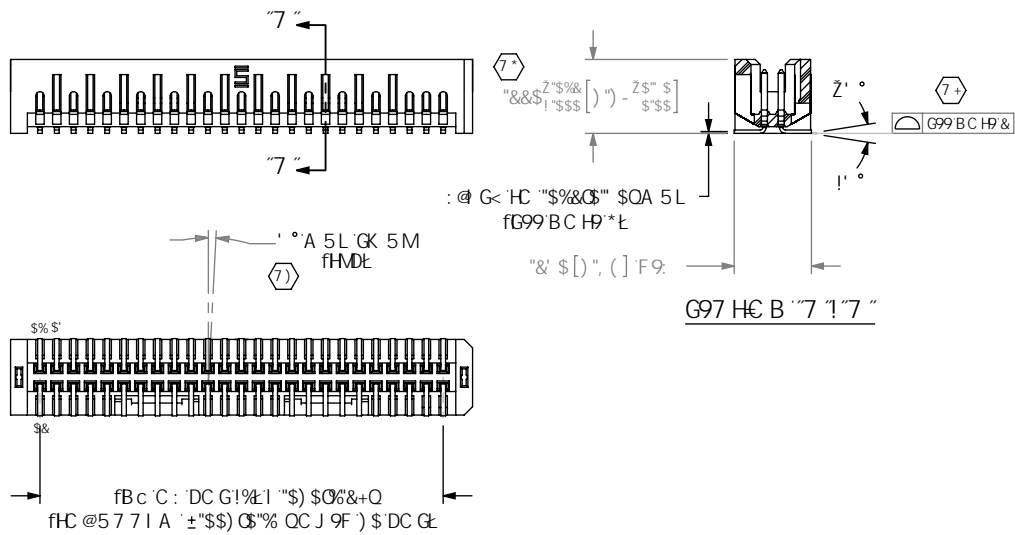

!S& G F: 579A C I BH  
fG<C K B. HA @%)!\$&LLL!8!  
fG5A 95G: = "%Z! B @GGC H: 9FK -69 G5 H98L

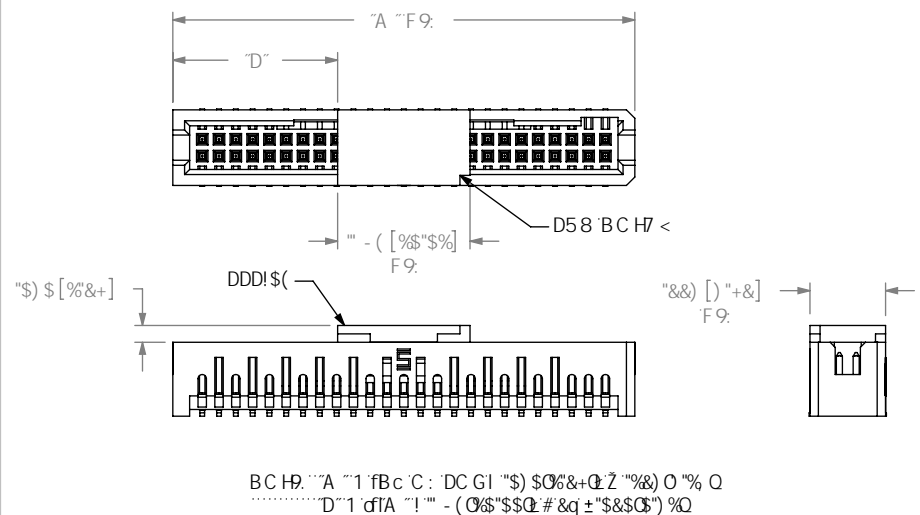

!D. D=? / D@579D58'C DHC B  
fG<C K B. HA @%)!\$&LLL!8!  
fG5A 95G: = "%Z! B @GGC H: 9FK -69 G5 H98L



!F5. F < H5B: @C DHC B  
fG<C K B. HA @%)!\$%LLL!8!F5L  
fG5A 95G: = "%Z! B @GGC H: 9FK -69 G5 H98L

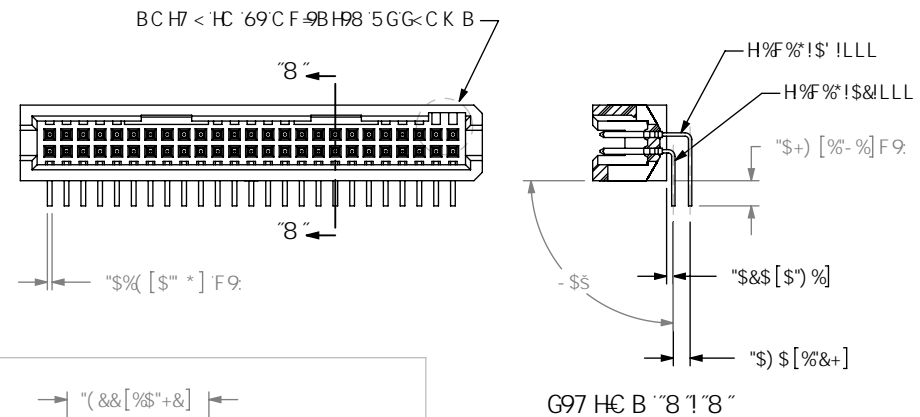

!?. DC @5A -89: @A 'D58'C DHC B  
fG<C K B. HA @%)!\$&LLL!8!  
fG5A 95G: = "%Z! B @GGC H: 9FK -69 G5 H98L

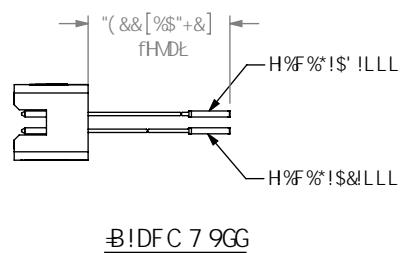
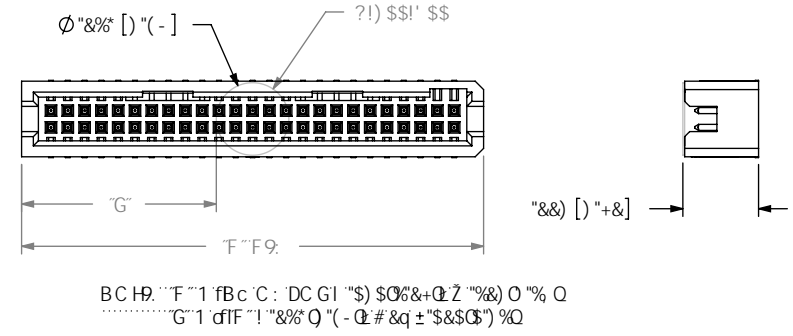

:PBK: PA 67 PA ?H PHA @%LLL!LLL!8!LLIA?HG@8FK

DFC DF 95 F M B C H9  
H: 6BC 71A 98H7 C B15 B G: CFA 5HC B  
7 C B: @98H5 95B8 DFC DF 945 F M C  
GSA H97 2 87 '5B8 G: 500BC H69 F90FC 81 7 98  
CF HF5BG 9F98 HC CH: 9F 8C 71A 98H6CF  
8 47 @C 98H HC CH: 9FGCF I 98: CF 5BM  
DI DFC 09 CH: 9F H: 5B H: 5HK <7 < #K 5G  
C 615 B 98 K #C I H: 9LDF 9098 K F #H8  
7 C B 98HC: GSA H97 2 87 "

8C 'BCHG7 5 @9 8FK B: B:  
G: 99HG7 5 @9 %+) %:



89G7 F DHC B:  
"\$) \$G<FC I 898 'H9FA -B5 @5GG9A 6@M  
8K: "BC"  
HA @%L!LL!LLL!8!LL  
6M 895BD (#, # - G<99H&C: (

D5FHGHC '69DCGHCB98'K #k 'DC @F#B; 'BC H7 <  
: 57 B; 'H-9G5AH7 'C; C '5B8 '5FFCK "

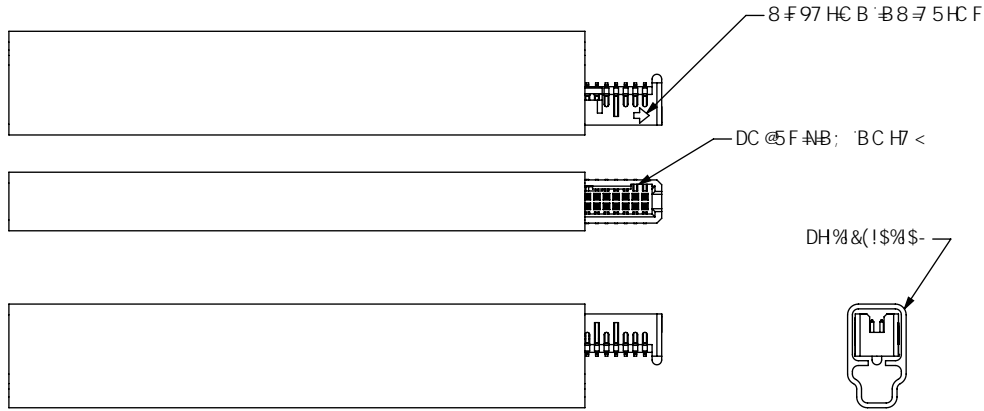

D5FHGHC '69DCGHCB98'K #k 'H5 @G: 57 B; 'C; C 'G89C:  
H 69'5B8 'DC @F#B; 'BC H7 < 'CF 9BH98 '5GG<C K B

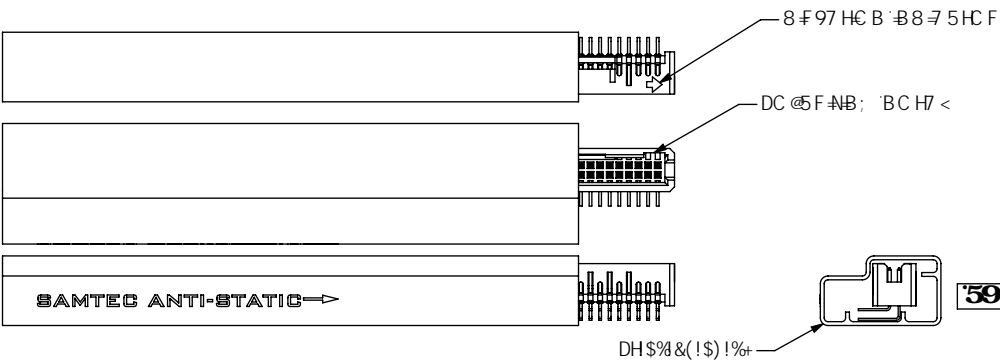

DC GHCB 'D5FHGK #k 'DC @F#B; 'BC H7 < 'CF 9BH98 '5GG<C K B

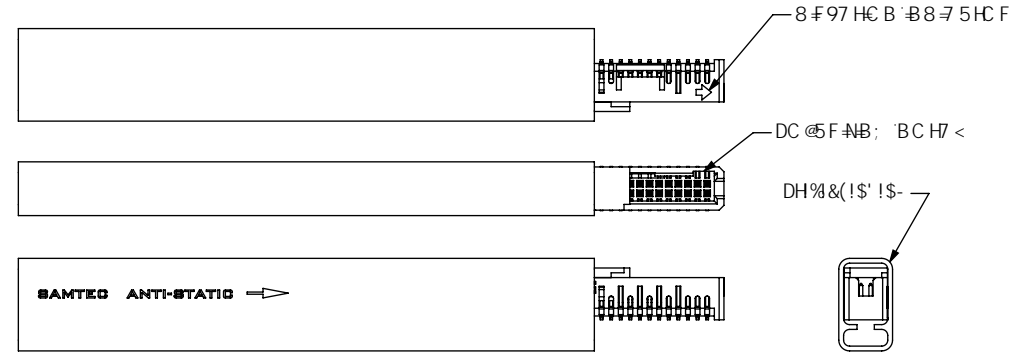

LEAD STYLE	PACKAGING TUBE	PLUG
-RA ONLY	PT-1-24-05-17	TP-07
-01,-02 EXCEPT -RA OR -P	PT-1-24-01-09	TP-24
-01-P,-02-P	PT-1-24-03-09	TP-03

: # " "+  
15. '5 @ BA 9BHD B 'C DHC B  
fG<C K B. 'HA @%&!)\$&LLL!8!5L  
fG5A 95G: # " %Z! B @GGC H: 9FK '69GH5H98L  
!BC H5J 5 @6 @K #k !F5

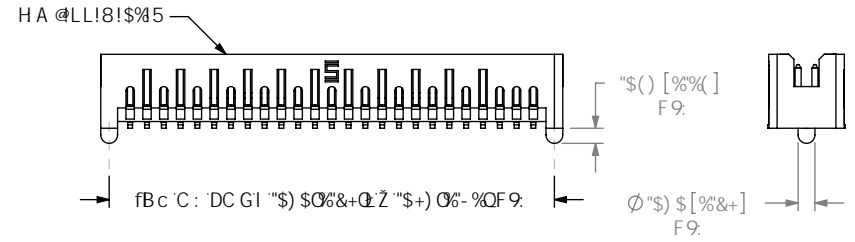

: # " "-  
!G5. 'GH5?98 '5 @ BA 9BHD B 'C DHC B  
fG<C K B. 'HA @%&!)\$&LLL!8!G5L  
fG5A 95G: # " %Z! B @GGC H: 9FK '69GH5H98L  
!BC H5J 5 @6 @C B !F5

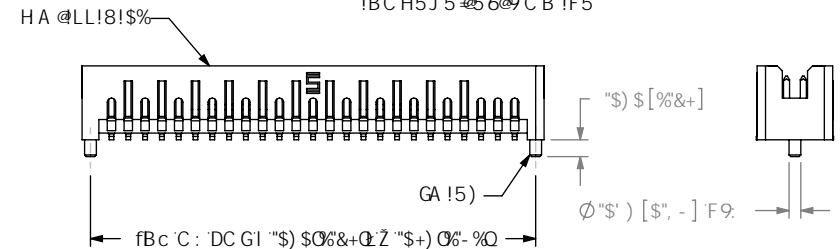

: # " "-  
!@. 'C 7?B; '7 @D C DHC B  
fG<C K B. 'HA @%&!)\$&LLL!8!@7L  
fG5A 95G: # " %Z! B @GGC H: 9FK '69GH5H98L  
!BC H5J 5 @6 @C B !F5

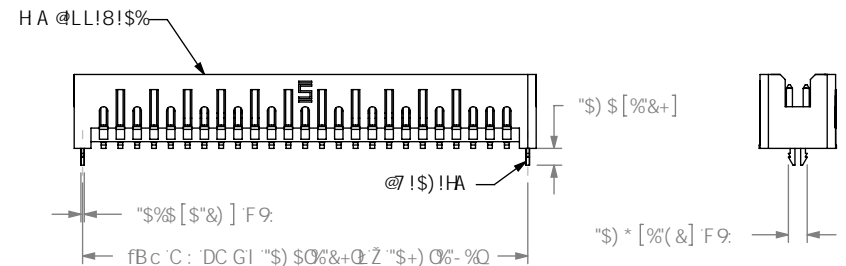

: P8K: PA @7 PA ?H PHA @%LLL!LLL!8!LLIA ?HG@8FK

DFC DF 95 FMB C H9  
H: G8C 71A 98H7 C B16 B G: CFA 5HC B  
7 C B: @98H5 95B8 DFC DF 95 FMB C  
GSA H97 2 87 '5B8 G-5 @BCH69 F90FC 81 7 98  
CF HF5BG 9F98 HC C H: 9F 8C 71A 98HC F  
8 47 @C 98H C C H: 9FGC F1 98: C F 5BM  
DI FDC 99 C H: 9F H: 5B H: 5HK < 7 < #K 5G  
C 615 B 98 K #k C1 H: 9L DF 9098 K F #H8  
7 C B 98HC: GSA H97 2 87 "

8C 'BCHG7 5 @9 8F5K #B:

G: 99HG7 5 @9 %+) .%



89G7 F @HC B.

"(\$) '\$G<FC I 8 98 'H9FA #B5 @5GG9A 6 @M

8K: "BC "

HA @%LL!LL!LLL!8!LL

6M 895BD (#, # -

G< 99H " "C: (

∓ "%\$  
!GB 'GC @8 9F 'DB 'C DHC B  
fG<C K B, HA @%&!) \$&LLL!8!GB L  
fG5A 9 5G: ∓ ""%Z! B@GG C H: 9F K -69 G5 H98 L  
fC B @M5 J 5 -6 6 @9 C B ! \$ & @95 8 'GM 9 L

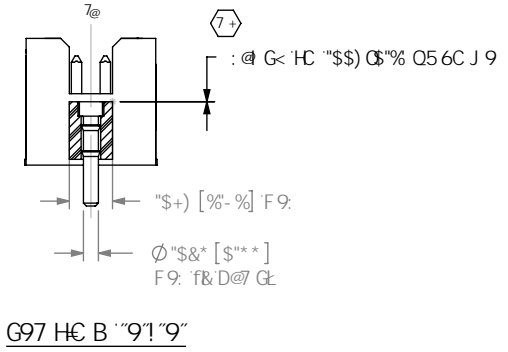
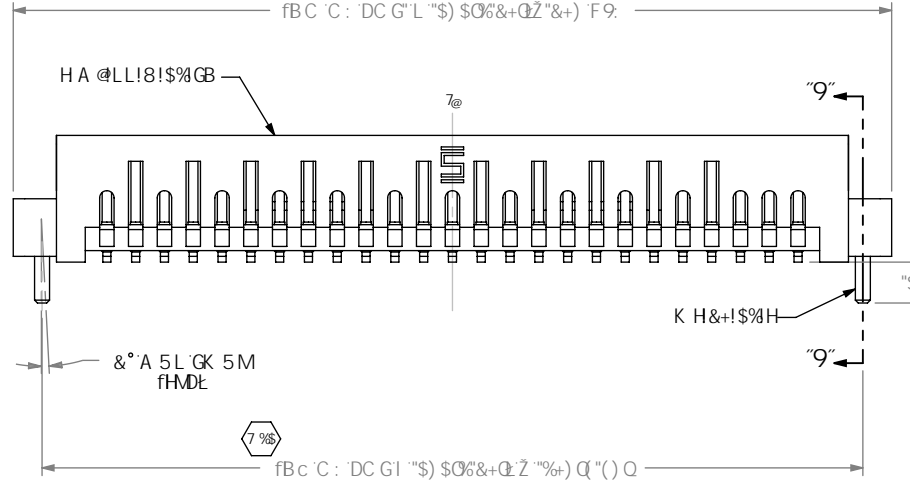

DFC.DF-95 FMBC H9  
H-6BC 71A 98H7 C B16 BG B-C FA 5HC B  
7C B: 898H5 9588 DFC DF 945 FMM C  
GSA H97 2 87 "588 G-5 88 BC H69 F90FC 81 7 98  
CF HF5BG 9F98 HC C H: 9F 8C 71A 98H6CF  
8 47 @C 98H C H: 9FGCF 1 98H : C F 58M  
DI FDC 69 CH: 9F H: 5B H: 5HK < 7 < +HK 5G  
C 615 B 98 K + K C 1 H: 9 9 L DF 9098 K F # 98  
7 C B 98HC : GSA H97 2 87 "

8C 'BCHG7 5 @9 8F5K -B;  
G: 99H7 5 @9 " . %

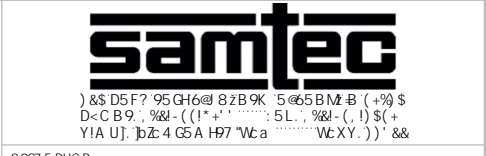

89G7 F DHC B.  
"\$) \$'G<FCI 898 'H9FA B5 @5 GG9A 6 @M  
8K : " "BC"  
**HA @% L I L L I L L I ! L L L**  
6M 895BD (#, # - G<99H('C: (